

Swivel Directional Blocks

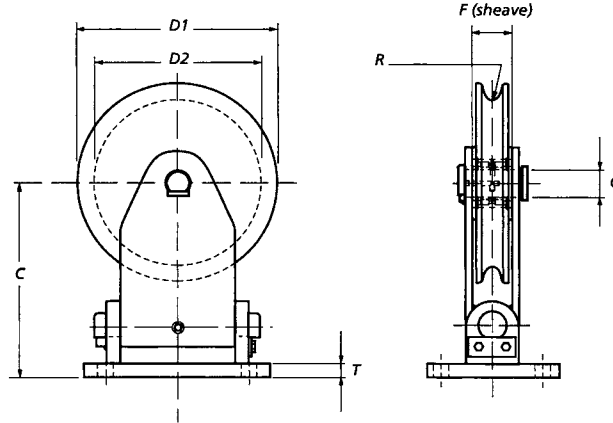

Cylindrical roller bearing

Bronze bushing

Stock No.	WLL (t)	Wire size up to (mm)	Bearing	Dimensions (mm)											Weight (kg)	
				D1	D2	A	B	C	F	G	H	T	R	TA		TB
25.125.01.50	1	10	Bronze	125	105	90	70	128	27	22	9	8	5.5	115	95	3.5
25.150.02.50	2	12	Bronze	150	120	115	85	160	40	30	11	10	6.5	140	110	6.5
25.200.03.50	3	14	Bronze	200	165	150	95	197	40	30	13.5	12	7.5	180	125	11
25.250.04.50	4	18	Bronze	250	210	190	120	240	45	35	17.5	15	9.5	230	160	21
25.300.06.50	6	20	Bronze	300	255	220	150	295	50	40	22	20	11	270	200	33
25.350.08.50	8	22	Bronze	350	305	270	160	350	50	45	26	25	12	330	220	52
25.400.10.50	10	24	Bronze	400	345	300	190	400	60	50	32	30	13	370	260	80

Minimum Ultimate Strength = 4 x WLL

Ball or cylindrical roller bearing

Stock No.	WLL (t)	Wire size up to (mm)	Bearing	Dimensions (mm)											Weight (kg)	
				D1	D2	A	B	C	F	G	H	T	R	TA		TB
25.125.01.51	1	10	2 x Ball	125	105	90	70	128	27	22	9	8	5.5	115	95	3.5
25.150.02.51	2	12	2 x Ball	150	120	115	85	160	40	30	11	10	6.5	140	110	6.5
25.200.03.51	3	14	2 x Ball	200	165	150	95	197	40	30	13.5	12	7.5	180	125	11
25.250.04.51	4	18	Straight	250	210	190	120	240	45	35	17.5	15	9.5	230	160	21
25.300.06.51	6	20	Straight	300	255	220	150	295	50	40	22	20	11	270	200	33
25.350.08.51	8	22	Straight	350	305	270	160	350	50	45	26	25	12	330	220	52
25.400.10.51	10	24	Straight	400	345	300	190	400	60	50	32	30	13	370	260	80

Minimum Ultimate Strength = 4 x WLL

WLL= Working Load Limit.

- No test certificate possible.
- Groove in sheave may be adjusted to other wire rope diameters.



SEE OUR WARNINGS AND APPLICATION INSTRUCTIONS

