

# **WARNING & SAFETY INFORMATION**

**GENERAL WARNING, USE, INSPECTION,  
MAINTENANCE AND SAFETY INFORMATION FOR  
LIFTING AND RIGGING COMPONENTS.**

**WARNING: THIS DOCUMENT CONTAINS IMPORTANT  
INFORMATION FOR THE SAFE AND PROPER INSTALLATION  
AND USE OF YOUR ROPEBLOCK COMPONENTS.**



**ROPEBLOCK**

**SMART GETS  
YOU FURTHER.**

# CONTENTS



<b>GENERAL</b> .....	<b>03</b>
Disclaimer .....	03
Manufacturer contact details .....	03
Contract information .....	03
<b>DEFINITIONS</b> .....	<b>03</b>
<b>HEALTH AND SAFETY WARNING</b> .....	<b>04</b>
<b>LIMITATIONS OF USE</b> .....	<b>05</b>
General .....	05
Design .....	05
Service life .....	05
Material .....	06
<b>WARNINGS AND INFORMATION ON USE</b> .....	<b>07</b>
Transport .....	07
Installation and reeving .....	07
Operation .....	07
Attaching the load .....	08
Tugging .....	08
Sockets .....	09
Turnbuckles .....	13
Rigging accessories .....	13
<b>CERTIFICATION</b> .....	<b>14</b>
General .....	14
<b>INSPECTION AND MAINTENANCE</b> .....	<b>14</b>
Spare parts list .....	15



## GENERAL



**THIS W&S DOCUMENT PROVIDES IMPORTANT INFORMATION CONCERNING THE TRANSPORT, INSTALLATION, USE, INSPECTION, MAINTENANCE AND SAFE USE OF YOUR ROPEBLOCK PRODUCT.**

This information is restricted to components used in lifting, rigging, tensioning or lashing intended to be used in lifting-systems or (quasi) static applications. Components typically comprise a head fitting (hook, stud-eye, clevis) and possibly sheaves and are used for lifting, lowering or pulling by applying tension to a wire rope or rope. Or comprise a product helping to connect the wire rope or other components to a structure, other components, or the wire rope itself. Possibly they are then used for lifting, lowering or pulling by applying tension to a wire rope or rope and as such holding and transferring the load.

Please examine your Ropeblock product, carefully read and understand the information presented and apply this information in practice. If you do not fully understand the information, DO NOT PUT YOUR PRODUCT INTO SERVICE. Please call your sales representative or Ropeblock B.V. directly.

## DISCLAIMER

Your Ropeblock product is by default considered a tool or essential part of the intended application and therefore defined by the application or system designer or application owner. In accordance with Machine Directive 2006/42/EC, it is therefore supplied as standard without EC declaration. Where applicable, the product will become part of a CE-marked assembly. The product must then not be put into service until the full assembly has been declared to conform to the provisions of 2006/42/EC. Where the product is considered a lifting accessory, requiring an individual conformity declaration (IIA) or declaration of incorporation (IIB), it should be mentioned in the contract.

The party installing Ropeblock products shall be competent and qualified in the design, construction or maintenance of the relevant application and have the knowledge of the relevant regulations and standards concerning the application/equipment required for proper installation, or be declared competent by their employer.

The party using Ropeblock products shall be competent and qualified in the operation of the relevant application and have the knowledge of the relevant regulations and standards concerning the application/equipment required for proper operation, or be declared competent by their employer.

Ropeblock is not responsible for any misuse of the products or misinterpretation of this document.

## MANUFACTURER CONTACT DETAILS

Ropeblock B.V.	Ropeblock B.V.
PO Box 391	Kampenstraat 1
7570 AJ Oldenzaal	7575 ER Oldenzaal
The Netherlands	The Netherlands

Phone: +31 88 532 32 00

Email: sales@ropeblock.com

## CONTRACT INFORMATION

Order confirmation is subject to Ropeblock's General Terms and Conditions of Sale and Delivery. These conditions are filed with the chamber of Commerce under number 060.78.445. Acceptance of our products implies acceptance of the Terms and Conditions in the contract. Definitions.

## DEFINITIONS

### SAFE WORKING LOAD (SWL)

The maximum load on the head fitting, as determined by a **competent person**, which an item of Lifting Equipment may raise, lower or suspend **under particular (operational/dynamic) service conditions**.

### ALLOWABLE LINE PULL (ALP)

The operational maximum line pull, as determined by a **competent person**, which an item of Lifting Equipment can be subjected to. For a single sheave block, this could also be referred to as SWL (as such, then not on the head fitting).

### WORKING LOAD LIMIT (WLL)

The maximum load on the head fitting, as determined by the **manufacturer**, which an item of Lifting Equipment is designed to raise, lower or suspend **under ideal (static) service conditions** with a given safety factor calculated against the MBL.

### MINIMUM BREAKING LOAD (MBL)

The load, checked by the **manufacturer** against the minimum theoretical failure strength of the material, at which an item of Lifting Equipment is designed to fail or break. (Or determined empirically in a laboratory breaking load test.) Also referred to as Minimum Breaking Force (MBF).

### FACTOR OF SAFETY (FOS)

Factor determined as the ratio between MBL and WLL. Also referred to as the Safety Factor (SF) or Design (Safety) Factor (D(S)F).\*



**DESIGN DYNAMIC FACTOR (DDF)**

The factor specified by the designer of the lifting appliance (e.g. crane). DDF is not the same as DAF, which is defined separately and applicable to a specific operation.  $DDF = \text{Design load} / \text{SWL}$ .

**DESIGN LOAD**

Load used for the purposes of design, derived by combining relevant characteristic load(s) (both static and dynamic) with appropriate load factor(s). The design load represents all foreseeable loads and combinations thereof (including all directions) that the lifting appliance will be subject to. Design load shall not be confused with SWL.

**PROOF LOAD (PL)**

The predetermined test load, greater than the SWL or WLL to which an item of lifting equipment is subjected before acceptance for use.

**DESIGN TEMPERATURE**

Reference temperature, specified by the designer of the lifting appliance, used as a criterion for the selection of material grades and properties.

**MINIMUM OPERATING TEMPERATURE**

Lowest temperature, determined by a **competent person**, the item of Lifting Equipment can be operated at without compromising safety.

**COMPETENT PERSON**

A **competent person** as defined in ISO 9927-1. To determine 'fit-for-use' the level 'Expert Engineer'\*\* is required. Alternatively, a qualified person nominated as such by their employer.

*\*Note:*

*The Factor of Safety is the actual MBL/WLL ratio the item itself has. The Design Factor is the MBL/WLL ratio required for the job the item is engineered to do. The FoS shall therefore be  $\geq DF$  and is in most cases the same.*

*\*\*Note:*

*An expert engineer is an engineer with experience in the design, construction or maintenance of cranes, sufficient knowledge of the relevant regulations and standards and the equipment necessary for carrying out the inspection. Furthermore, an expert engineer is an engineer who is in a position to judge the safe condition of the crane and to decide which measures shall be taken in order to ensure continued safe operation.*

Particular service conditions are defined in combination with the applicable design standards or rules. With regard to WLL, the client shall act as the competent person to establish fit-for-use under the given particular

service conditions against the factor of safety of the item of lifting equipment.

With regard to MBL, the client shall act as the competent person to establish the SWL in conjunction with the given particular service conditions.

**HEALTH AND SAFETY WARNING**



The party installing Ropeblock products shall be competent in the design, construction or maintenance of the relevant application and have the knowledge of the relevant regulations and standards concerning the application/equipment required for proper installation, or be declared competent by their employer.

The party using Ropeblock products shall be competent in the operation of the relevant application and have the knowledge of the relevant regulations and standards concerning the application/equipment required for proper operation, or be declared competent by their employer.

NEVER USE THE PRODUCTS IF THE CONDITIONS STATED IN THIS DOCUMENT ARE NOT FULFILLED OR IF YOU DO NOT UNDERSTAND THE INFORMATION PRESENTED.

During transportation and handling, a crushing, shearing or dropping hazard exists.

Care shall be taken when installing, working with or repairing lifting or rigging equipment. If installed or used incorrectly or if a repair is executed incorrectly, loss of stability, falling objects, insufficient mechanical strength or failure of parts could occur and inflict injury or death.

Where your Ropeblock product has swiveling and moving parts, there are potential crushing, shearing or entanglement hazards.

When the product is in use do not put hands:

1. Between sheaves, side plates, guards, wire rope or other moving parts.
  2. In the area of becket, hook, hook nut or cross head.
- Workers must be made alert and wear proper safety gear at all times. Take great care to avoid clothing becoming trapped or snagged. Pay attention to sharp edges.

Repairs shall be carried out by competent and trained personnel only. Power shall be switched off and stored energy eliminated, before repair activities are carried out. Work shall only take place with the product on a firm surface with the product secured. Always follow local rules and regulations.

## LIMITATIONS OF USE

### GENERAL

NEVER STAND UNDER THE LOAD.

The Safe Working Load (SWL), Allowable Line Pull (ALP) and Working Load Limit (WLL) shall never be exceeded.

Unless otherwise stated, only fully reeved crane blocks may be loaded up to the rated SWL or WLL. For partial reeving, the load shall always be symmetrically distributed to eliminate tilt, fleet angles and consequent side loading. Reeving shall be carried out by competent personnel only.

Always understand the weight you are lifting and the SWL or WLL of your system and components. The SWL or WLL shall exceed the weight of the intended load you plan to lift, including its rigging.

Swivels and overhaul balls may be loaded up to the rated SWL or WLL and should only be used with rotation-resistant wire ropes. If in doubt, contact your wire rope sales representative for further guidance.

Capacity ratings apply to new products or products considered to be in an "as new" condition by a competent and qualified person. Capacity may be affected by wear, misuse, corrosion, impact deformation or modification.

Hook blocks, overhaul balls and swivels shall be used only in vertical lift as they are only designed for this purpose. Side loading may create unacceptable stresses in the component.

Swivels may be used in any orientation when specifically designed for this.

Rigging blocks shall be used in accordance with design specifications and are generally intended for tension and pulling. Blocks shall not be used for towing unless specifically designed and marked for that purpose.

Horizontal and vertical lead sheaves shall be used as indicated in the product description or drawings.

Side loading is prohibited as it may create unacceptable stresses in the component. Shock or side loading shall not be applied unless the product is designed for this purpose.

Skew loading shall be kept to a minimum for undetermined loads. The center of gravity of the load shall be aligned with the hook shank centerline. (See the section on lashing of the load.)

The load shall always be placed in the seat or bowl of the hook or eye. **NEVER AT THE POINT.** The latch shall never be allowed to carry the load.

### DESIGN

Your Ropeblock product was designed in accordance with the standards and design rules as stated in the contract and/or drawings and/or with knowledge of industry standards (in part or whole) where applicable and can as such be considered state-of-the-art.

Design parameters such as SWL or WLL, load group or factor of safety, wire rope size, weight and design or operating temperature must be visible on the product tag plate, or be engraved, or be traceable back from the certificate or contract by its serial number. **DO NOT USE YOUR PRODUCT WITHOUT THIS INFORMATION.**

WLL equipment is by default designed with a FoS of 4:1 unless specified otherwise on the tag plate.

Appropriate overhaul weight, if required, may vary due to crane design, geometrical design, materials, wire rope selection, and environmental circumstances such as temperature.

Sheave bearings should have separate lubrication channels if your Ropeblock product is to be used in a maritime, offshore, or otherwise significantly corrosion aggressive environment.

### SERVICE LIFE

Generically designed products (WLL products) should meet their normal service life when used in their intended application. Check with your sales representative for information.

Specifically designed products (SWL products) should meet their intended service life according to the prescribed design standard or 3rd party rules from the application or system designer.

The service life of Ropeblock products will significantly depend on the actual intensity of use, or possible misuse. Monitoring for wear and reduced capacity is essential for continued safe operation (see the section on inspection and maintenance).

Special consideration is required for vibration work or pile driving work as this may significantly increase load cycles and promote early fatigue and/or even premature failure in relevant components depending WLL of the equipment



and the actual workload. Round Overhaul Balls shall not be subjected to high vibration. Optional features like detachable,- or interchangeable cheek weights shall be removed prior to operation with vibration equipment or pile driving equipment unless specifically designed and confirmed by Ropeblock B.V. in writing to work with it.

#### **MATERIAL**

For generically designed products (WLL products), the operating temperature limits are  $-40^{\circ}\text{C}$  /  $+80^{\circ}\text{C}$  with steel or iron sheaves\*. The structural materials in these blocks provide suitable ductility for use at the stated temperatures with 100% capacity and at normal speed of operation.

\*Note:  $-30^{\circ}\text{C}$  /  $+50^{\circ}\text{C}$  applies for equipment with nylon (Pa6G) sheaves.

For use in applications or environments other than those originally intended, please contact your sales representative or Ropeblock B.V.

Products specifically designed in accordance with prescribed design standards or 3rd party rules (SWL products) will possess adequate ductility in their materials as specified at the reference design temperature in those standards or rules.

Components from grade 8 upwards must not be used in highly alkaline ( $>\text{pH}10$ ) or acidic conditions ( $<\text{pH}6$ ). Comprehensive and regular examination shall be carried out when they are used in severe or corrosion inducing environments to prevent hydrogen embrittlement and consequent severe loss of ductility and/or premature failure.

All Ropeblock products are asbestos-free.

If in doubt, please contact your Ropeblock sales representative for the relevant drawings and information.



## WARNINGS AND INFORMATION ON USE

### TRANSPORT

The products shall be handled with care. Depending on the surface it is placed on, the product may tilt and tip over, roll or slide. A potential crushing hazard exists.

Lifting or lashing points shall be used for their intended purpose only. **NEVER USE IN OR WITH THE APPLICATION.** Use other lifting equipment to handle the product if required.

### INSTALLATION AND REEVING

Always verify that the product is in its proper and intended condition suitable for your application.

Reeving shall be performed on a firm surface to prevent the block from tipping over.

Only fully-reeved crane blocks may be loaded up to the rated SWL or WLL. For partial reeving, the loads shall always be symmetrically distributed to eliminate tilt, fleet angles and consequent side loading. Reeving shall be carried out by competent personnel only.

Typical efficiency losses for sheaves with roller bearings and wire rope are 2% per wire rope bend. Actual efficiency losses may vary due to crane design, load, block weight, geometrical design, material, wire rope selection and environmental conditions.

Admissible fleet angles shall be monitored according to the relevant standards. They are typically 4° for non-rotation resistant wire rope and 2° for rotation resistant wire rope.

The wire rope selected for your application shall be suitable for the Ropeblock product and the dimensional factors in your system. Reeving shall be in accordance with the crane or system designer's diagram.

The sheave groove geometry shall not hinder proper function with the prescribed wire rope. According to EN 13135, for a new build the radius should be within half the nominal wire rope size + min. 5% / + max. 12%. Check your actual sheave radius with the nominal wire rope size before installation.

Avoid wire rope from becoming damaged during installation. The wire rope shall be seated in the groove of the sheave before closing the reeve guides. Make sure all reeve guards are closed and secured.

Poor wire rope installation may affect the proper functioning of your Ropeblock product resulting in cabling (rotation of the block until the wire ropes are entangled).

Overhaul balls and swivels should only be used with rotation-resistant wire ropes. If in doubt, contact your wire rope sales representative for further guidance.

Ensure your end-of-line switch is functioning properly or other means have been implemented to prevent two-blocking. The lower block shall not come into contact with the upper block or sheave arrangement of the crane unless a receiver on the crane, the crane and the block itself were designed for this purpose.

Make sure all optional features (additional weights, sheaves, pins, etc.) are properly secured. If in doubt, contact your sales representative or Ropeblock.

Lifting points on optional features are designed for ONE unit only. **NEVER PICK STACKED UNITS WITH ONE LIFTING POINT.** Do not add components or mass to the product unless it has been designed by Ropeblock and intended for this purpose.

### OPERATION

Always follow the prescribed inspection protocols and ensure that the product condition complies with the requirements for the job and the product has been properly maintained.

The Safe Working Load (SWL), Allowable Line Pull (ALP) or Working Load Limit (WLL) shall never be exceeded.

To ensure structural integrity of the product, only fully closed and properly fitted products may be put into operation in your system. All locks, pins and retainers shall be properly assembled and/or tightened prior to any operation to eliminate potential falling objects or loads that may inflict injury or death.

Always understand the weight you are lifting and the SWL or WLL of your system and components. The SWL or WLL shall exceed the weight of the intended load you plan to lift, including its rigging.

Crane blocks shall be used in vertical lift. Shock or side loading shall not be applied. Prevent your product from coming into contact with any structure or object during a lift since this could result in a loss of load.



Optional features like detachable,- or interchangeable cheek weights shall be removed prior to operation with vibration equipment.

Skew loading the hook shall be kept to a minimum for undetermined loads. The center of gravity of the load shall be aligned with the hook shank centerline.

Ensure that the hook rotates freely under load, and that your reeving is able to generate the required counter momentum for the thrust bearing to prevent cabling. Do not rotate hooks, eyes or other suspensions with only a washer (i.e. without a bearing) under load. Ensure you are following the applicable local and national regulations.

**ATTACHING THE LOAD**

The lashing or rigging arrangement of the load shall be limited to a 90° included angle between two slings and the maximum single sling angle (from vertical) shall be less than 45° for single hooks and less than 60° for ramshorn hooks. Forces in slings shall be limited to the following:

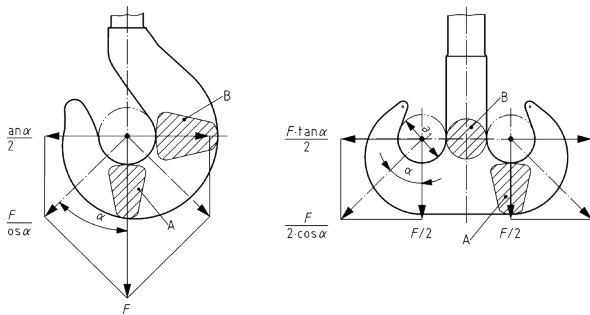

Skew loading shall be avoided by adjusting the rigging arrangement below the hook to allow the center of gravity of the load to line up with the centerline of the hook shank. The hook shall receive symmetrical vertical loads to minimize additional stress due to the bending of the hook shank.

If there is foreseeable misuse of skew loading, this shall be limited to the maximum permitted fleet angles of the wire rope in your system. The skew load factor shall at all times be less than 1.25. (50/40 load distribution in a ramshorn hook.) Skew loading may induce poor hook swivelling performance.

When considered applicable to your application, detailed lashing limits analysis should be undertaken in accordance with EN 13001-3.5 and be communicated to the operators.

The lashing or rigging arrangement shall at all times be in accordance with acceptable practice and be appropriate to the application and intended lift.

The wire rope slings shall be selected to be appropriate to the hook and its seat-bending radius. This D/d ratio shall be in accordance with acceptable practice. Depending on the wire rope, a D/d ≥ 1 typically applies for 6x19 or 6x37 Flemish eye slings (loop) and greater than this for basket hitches.

Check the D/d ratio and the effect on sling capacity with your wire rope or sling manufacturer. Alternatively, use master links or other hardware to ensure your slings maintain the required strength for the lift. See e.g. ISO 8792 for further guidance.

We recommend using hardware that matches the shape of the hook / counterpart to prevent damage to the hook seat or bowl / counterpart.

The use of fibre slings should be verified with the manufacturer of the sling.

Latches shall be closed during the lift. NEVER LOAD A LATCH.

**TUGGING**

If tugging is a mode of operation, this shall be such that the rigging, and consequently the Ropeblock product, is free from significant forces perpendicular to the vertical hoisting forces from the load. Perpendicular forces are a side load and create a bending moment. Unless specifically indicated, your product is not designed for this. Tugging lines are intended only to hold the product in position.



## SOCKETS

### GENERAL

Safety measures should be taken into account when using our sockets. Carefully follow all installation instructions. Important information can be found below.

Ropeblock sockets provide adequate ductility and should be considered fit for purpose until minimum operating temperatures of -40°C in general service application. Check your application specific criteria with the set design temperature against the specifications set forth in the applicable design standards or rules. Ropeblock sockets meet or exceed 42J/-20°C Charpy “V” impact values.

Excluding limitations set forth by the wire rope and/or resin or spelter material as described in the EN and ISO standards (typ. 80°C for fibre core ropes and 110°C for resin), sockets will be affected by higher temperatures too, but continue to serve with below approximate limited work load capacity rating at these elevated temperatures.

110°C with 100% capacity rating  
 150°C with 92% capacity rating  
 200°C with 83% capacity rating  
 250°C with 75% capacity rating  
 300°C with 67% capacity rating

Your application requires compensation for this. For intermittent use at elevated temperatures the temperature the socket body will reach should be determined. Use above 300°C is not recommended, contact Ropeblock for further guidance.

Dimensional tolerances depend on the manufacturing techniques applied and are different between machined components (pins) and cast components (socket bodies and wedges). Also surface finish e.g. hot dip galvanizing or even paint may add to the overall thickness and fork distance. Please contact Ropeblock for further guidance and a detailed dimensional tolerance sheet.

All spelter sockets and wedge sockets receive the vigorous Ropeblock Non Destructive Testing (NDT) regime. This working program is covering both surface inspections (MT and visual) as well as volumetric inspections (UT). Volumetric RT inspections can be done on request. Certificates are available when so ordered.

Socket(pin)s may be used as an orientating hinge-point. To prevent excessive wear and additional rope bending they should not be used as a friction hinge point under load. Further design evaluation and creating a proper functional

hinge point is advised. Check for potential pin rolling with axial movement that may develop depending operation.

- ❑ **ALWAYS CARRY OUT A VISUAL INSPECTION BEFORE USING A SOCKET AND PIN.**
- ❑ **NEVER USE A PART SHOWING CRACKS OR DAMAGES.**
- ❑ **DO NOT SIDE-LOAD A SOCKET.**
- ❑ **REPAIRS ARE NOT ALLOWED; FOR CONSULTATION CONTACT ROPEBLOCK.**
- ❑ **NEVER SHOCK-LOAD A SOCKET.**

### PROOF TESTING INDIVIDUAL SOCKETS

Sockets can be individually proof tested on request. The default proof load value is 40% of the catalogue MBL for spelter sockets and 30% for wedge sockets. Higher values until 50% will require special consideration.

### PROOF TESTING SOCKETED ASSEMBLIES

Per EN 13411-4:2011 type testing may be required. Please see the standard and annex C and F for further guidance. (Alternatively ISO 17558:2006.) Depending the application, end-user requirement and / or local regulations, socketed assemblies may require to be proof tested individually with a proof load relative to the Work Load Limit or Safe Working Load assigned to the socketed assembly.

### SPELTER SOCKETS

- Proper spelter socket terminations have an efficiency equal to the breaking load of the wire. This can be limited by the minimum breaking load of the socket (MBL), as mentioned in the tables
- For further performance specifications, see our type approvals
- Please read the instructions of the resin manufacturer carefully before use. Incorrect use of the resin or spelter material can result in an unsafe termination. Look for the expiration date of the resin. More information can also be obtained from your wire rope supplier
- Always remove any dirt and grease from the wire rope broom and socket basket
- Ensure that the broomed wires are evenly spaced in the basket and that the wire and basket are aligned with each other
- When using white metal or zinc, the socket may be preheated up-to 350°C (660°F)
- Make sure the base of the socket is properly sealed. This to prevent resin leakage, which may cause voids
- It is recommended to pour on one side as this will help eliminate air bubbles being formed
- Check for proper penetration of the resin to the bottom. Recommendation to use a 1mm probe wire between the strands to validate resin penetration if possible.
- Re-grease the wire rope at the neck.



- Never use an assembly before the resin is fully hardened
- Procedures in EN 13411-4 or ISO 17558 or equivalent should be followed
- Socketing should always be executed by qualified and competent personnel only

**ADDITIONAL FOR FAST CONNECTOR SOCKETS**

- The FCS Spin Resistant connector shall be used with non-rotation resistant wire rope and may be used with rotation resistant wire rope
- The FCS standard (rotating) connector shall be used with non-rotating or cat 1. rotation resistant wire rope only
- Normal socketing procedures for spelter sockets shall be followed
- Remove seizing after and up to the bottom of the basket when the seizing is in contact with the housing.
- The lugs are not a lifting device; they are designed to fit a tool used to pull the connector through the reeving system with a standard shackle. One may leave the tool once assembled if clearance in the application allows for it.

**ADDITIONAL FOR SUPER REEVE CONNECTOR SOCKETS**

- The SCS Spin Resistant connector shall be used with non-rotation resistant wire rope and may be used with rotation resistant wire rope
- The SCS standard (rotating) connector shall be used with non-rotating or cat 1. rotation resistant wire rope only
- The basket length differs from normal. Measure appropriately for required broom height. Seizing should match your working method
- Use a cover to protect the thread
- Resin penetration may be more difficult in the tight SCS buttons, esp. with large fill factor ropes with a large number of wires (e.g. high performance ropes like 35x7). Normal socketing procedures for spelter sockets shall be followed with the addition of the following recommendations for resin:
  - Do NOT use booster packages to speed up curing.
  - Reduce mixing time when possible, but keep resin mfg instructions.
  - At higher ambient temperatures we recommend to refrigerator cool the resin to delay curing / increase gel time. And if possible to cool the pre-assembly too to the same temperature as the resin. Follow resin manufacturers limitations.
- It is recommend to stay out of direct sunlight on hotter days.
- Suggest to use low viscous resin. (typ. found in smaller cans.)
- Suggest wire ‘poking’ around in the socket basket, as you pour, which should release air bubbles more easy and promote resin penetration to the bottom.

- To prevent air becoming trapped, consider pouring without putty at the bottom and placing the putty once the resin comes out at the bottom. (Two pair of hands needed.)
- Remove seizing after and up to the bottom of the basket when the seizing is in contact with the housing.
- The connector cap shall be secured after socketing by means of a high strength thread locking adhesive. (E.g. Loctite 270, etc.)
- The connector cap is not a lifting device; it is used to pull the connector through the reeving system with a standard shackle.
- The connector shall always be installed in the socket housing and used with the retainer properly mounted and secured.
- The SCS connector is not recommended for re-use.

**APPROXIMATE RESIN VOLUMES**

For wire rope Ø		Approximate resin volume
mm	inch	cc
6 - 7	¼	9
8 - 10	⅜	15
11 - 13	½	35
14 - 16	⅝	50
18 - 19	¾	80
20 - 22	7/8	120
23 - 26	1	160
27 - 30	1 ⅛	220
31 - 36	1 ½ - 1 ⅜	350
37 - 39	1 ½	425
40 - 42	1 ⅝	500
43 - 48	1 ¾ - 1 7/8	700
49 - 54	2 - 2 ⅛	1200
55 - 60	2 ¼ - 2 ⅜	1450
61 - 68	2 ½ - 2 ⅝	1850
69 - 75	2 ¾ - 2 7/8	2250
76 - 80	3 - 3 ⅛	3500
81 - 86	3 ¼ - 3 ⅜	4000
87 - 93	3 ½ - 3 ⅝	5000
94 - 102	3 ¾ - 4	7500
108 - 115	4 ¼ - 4 ½	10500
120 - 130	4 ¾ - 5	14000
135 - 140	5 ½	16000
141 - 153	5 ¾ - 6	20000
154 - 165	6 ¼ - 6 ½	26000
166 - 178	6 ¾ - 7	33000
179 - 191	7 ¼ - 7 ½	39000
192 - 204	7 ¾ - 8	48000

**WARNINGS**

- ALWAYS CARRY OUT A VISUAL INSPECTION BEFORE USING A SOCKET AND PIN.
- NEVER USE A PART SHOWING CRACKS.
- DO NOT SIDE-LOAD A SOCKET.
- REPAIRS ARE NOT ALLOWED, FOR ANY REPAIRS CONTACT YOUR SUPPLIER.
- NEVER SHOCK-LOAD A SOCKET.

Required resin volume for socketing wire rope terminations

**WEDGE SOCKETS**

- Always mount the loaded part of the wire in the centre line of the pin (see figures below).
- Make sure you are using the correct house, rope and wedge size combination.
- Nominal intermediate rope sizes should be used with the biggest socket within the range.
- Secure properly the dead end with a wire rope clip.
- Do not attach the dead end to the live wire.
- The dead end should have a length of 6 times the wire diameter with a minimum of 150 mm.
- Ensure that the wire rope and wedge are fully seated after the first load.
- A load may slip if the connection is not properly installed.
- Inspect the connection regularly.
- The efficiency of a 6 or 8 strand wire rope and most high performance ropes with a Ropeblock wedge socket connection is 80% of the MBL of the wire rope, but limited to the MBL of the socket.
- Check your wire rope supplier for efficiency rating details when used with high performance ropes or test the assembly type to determine efficiency.

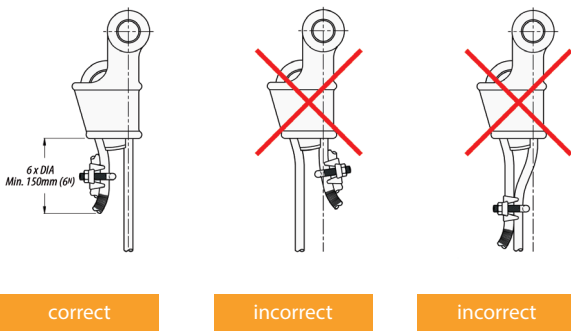

- After mounting the wire rope in a loop through the OWS socket, place the wedge correctly in the socket.

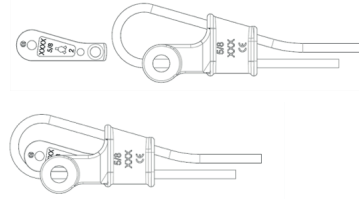

- Pre-tension the wire rope, so that wedge is fixed inside the socket housing.
- Mount the wire rope clip on the dead end section, gripping the tail of the wire rope.

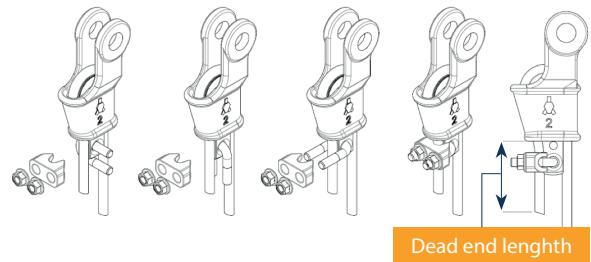

- The dead end length or tail length should be a minimum of:
  - Standard 6-8 Strand Wire Rope**  
Minimum of 6 rope diameters, but not less than 150mm.
  - Rotation resistant Wire Rope**  
Minimum of 18 rope diameters, but not less than 150mm.
- Tighten nuts on clip to recommended torque.

OWS Type	0,5	1	2	3	4	5	6	7
Wire rope clips Type*	10	13	16	19	22	26	30	34
Torque [Nm]	9	33	49	68	107	147	212	296

\* Clips per EN 13411-5

**TAILGRIP WEDGE SOCKETS**

- Check that the wire rope is suitable for the socket application.
- Check that socket, wedge and wire rope clip match to fit the wire rope size. The correct wire rope size can be checked with the Go - No Go feature, implemented in the wedge.
  - The wire rope **MUST** pass thru the 'Go' hole in the wedge.
  - The wire rope shall **NOT** pass thru the 'No-Go' hole in the wedge.

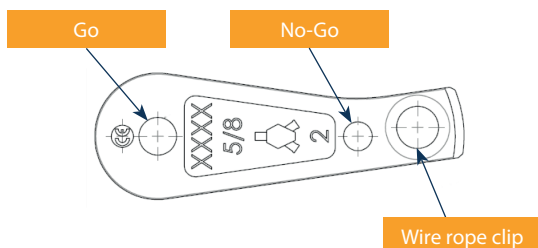

**SWAGE SOCKETS AND SLEEVES (FLEMISH EYE FERRULE)**

- Swage Sockets and Sleeves are recommended for use on 6 x 19 or 6 x 37 IPS or XIP (EIP), XXIP (EEIP), RRL, FC, or IWRC wire ropes. They are also approved for use on galvanized bridge rope. They are not recommended for use on fibre core ropes without further measures.
- Properly applied Swage Sockets may reach an efficiency rating of 100% and shall have a minimum efficiency of 90% per EN 13411-8. This rating is based on the catalogue strength of wire rope. This can be limited by the minimum breaking load of the socket (MBL).
- Swaged sleeves should generate an efficiency of at least 90% per EN 13411-3.
- For further performance specifications, please contact Ropeblock.
- Swage sockets and sleeves are forged from special steel quality and heat treated for cold swaging.
- Proper swaging methods must be followed for all Swage Sockets and Sleeves.
- Always use the matching dies to the socket or sleeve.



- Ensure the dies are aligned and within the limits for admissible wear.
- The position of the rope end should be verified prior to swaging and after swaging.
- Multiple progressive pressings are required to prevent flash, which could develop into a permanent mark or possibly a crack in the sleeve. A color change will not indicate proper swaging.
- A light oil lubricant should be applied to each die and wiped clean after swaging.
- For swaging practice details contact the die manufacturer.
- Always verify after swaging dimensional limits.
- Each swaged termination shall be free of any flaws and surface defects and shall not exhibit any sharp edges or rough surfaces.
- The outline of EN 13411-3 / EN 13411-8 or equivalent should be followed.
- Caution: Proper swaging practices are the responsibility of the sling manufacturer.
- Before using Swage Sockets or Sleeves with other type lay, construction or grade of wire rope, it is recommended that the termination be type tested to prove the adequacy of the assembly.
- For Flemish eye constructions we recommend to follow internationally prescribed construction, safety criteria and inspection procedures. (e.g. EN 13414, ISO 8792 and ASME B30.9).



## TURNBUCKLES

### GENERAL

Safety measures should be taken into account when using turnbuckles. Carefully follow all instructions. Important information can be found below.

Turnbuckles are primarily used as adjustable hardware to tension two points and/or possibly adjust the distance between two points.

All turnbuckles have a Factor of Safety (FoS) of 5:1.

Ropeblock closed body trapezium thread turnbuckles (TR series) may be used for lifting, general rigging and lashing.

Open body UNC thread and closed body metric thread turnbuckles should be used for general rigging and lashing only.

Ropeblock turnbuckles provide adequate toughness and ductility and should be considered fit for purpose until minimum operating temperatures of -40°C in general service application. Check your application specific criteria with the set design temperature against the specifications set forth in the applicable design standards or rules.

Ropeblock turnbuckles can be used with below approximate limited work load capacity rating for continuous service at these elevated temperatures.:

- ≤ 110°C with 100% capacity rating
- ≤ 150°C with 92% capacity rating
- ≤ 200°C with 83% capacity rating
- ≤ 250°C with 75% capacity rating
- ≤ 300°C with 67% capacity rating

For intermittent use at elevated temperatures the temperature the turnbuckle will reach should be determined. Use above 300°C is not recommended; Contact Ropeblock for further guidance. Please note that the grease on the thread will lose effectiveness above ±80°C.

Dimensional tolerances depend on the manufacturing techniques applied and are different between machined components (pins) and forged components (bodies and end fitting). Also surface finish e.g. hot dip galvanizing or even paint may add to the overall thickness and fork distance. Please contact Ropeblock for further guidance and a dimensional tolerance sheet.

Turnbuckles should be tensioned in line only (straight pull), unless designed specific for that purpose.

Turnbuckle connection points may be used as an orientating hinge-point.

To prevent excessive wear and additional bending they should not be used as a friction hinge point under load. Further design evaluation and creating a proper functional hinge point is advised.

Check for potential pin rolling with axial movement that may develop depending operation.

Check your application for the required take-up length and used connecting points (jaw, stud-eye, oblong-eye, rod or stud ends, hook, etc.).

Depending your application select proper the retaining option (contra nuts or locking/retainer bolts). Consider the rotational characteristics of wire rope where applicable. After assembly, make sure locking nuts or locking/retainer bolts are properly tightened. Use proper inspection routines when used on vibrating equipment. A yearly inspection as a minimum is advised.

The absolute minimum thread engagement is 1xd (with d being the thread size). This must be measured on both sides of the turnbuckle and based on the actual dimensions.

Protect the turnbuckle against corrosion and maintain proper grease levels on the bare metal threads.

- ❑ **ALWAYS CARRY OUT A VISUAL INSPECTION BEFORE USING A TURNBUCKLE.**
- ❑ **NEVER USE A PART SHOWING CRACKS OR DAMAGES.**
- ❑ **DO NOT SIDE-LOAD A TURNBUCKLE.**
- ❑ **REPAIRS ARE NOT ALLOWED; FOR CONSULTATION CONTACT ROPEBLOCK.**
- ❑ **NEVER SHOCK-LOAD A TURNBUCKLE.**

### PROOF TESTING

Turnbuckles can be individually proof tested on request. The default proof load value is twice the catalogue WLL of the turnbuckle and 1,22xWLL + 20 for WLL above 25t for the trapezium turnbuckles. Higher or different values and/or individual testing for UNC or metric turnbuckles upon request.

### RIGGING ACCESSORIES

To other rigging accessories such as tri-plates, split overhaul balls, pad-eyes, devils claws, etc. the limitations of use and further relevant sections of this warning and safety document apply and are to be used in a straight pull only. Contact Ropeblock for guidance if so required.



## CERTIFICATION

### GENERAL

The following certificates or other documents, where applicable or so ordered, have been provided with the product:

- Declaration of compliance with the order EN 10204 2.1
- Test report EN 10204 2.2 (Batch (proof load) test (according to ILO 152)
- Inspection certificate finished product EN10204 3.1 (Individual product (proof load) test (according to ILO 152)
- Inspection certificate finished product EN10204 3.2 (Individual product (proof load) test (according to ILO 152), including conformity survey by a 3rd party)
- Hook material certificate EN 10204 3.1
- Material certificate EN10204 3.1 for main load bearing part
- Material certificates EN10204 3.1 for all load bearing parts
- Documents per contract / etc.

## INSPECTION AND MAINTENANCE

Inspections should be carried out daily or weekly or, if your Ropeblock product is used infrequently, each time it is used by the operator. Examination of the product by a competent and trained person should be carried out monthly to check for damage, corrosion and the free movement of sheave and safety latch. Thorough examination of the product by a competent and trained person should be carried out annually or periodically depending on usage intensity as seen fit by the application designer or owner.

**DEPENDING ON LOCAL REGULATIONS, PRODUCTS (E.G. HOOK AND HOOK-NUT) ARE TO BE DISMANTLED, INSPECTED AND RE-TESTED (PROOF LOADED) AT LEAST EVERY 4 OR 5 YEARS.**

**WITH THE MANDATORY DISMANTLING INSPECTION OF THE HOOK, THE OVERALL BLOCK AND COMPONENTS WITH SHEAVE AND BEARINGS SHOULD BE INSPECTED FOR PROPER FUNCTIONING AND CONDITION.**

Particular attention shall at least be paid to the following:

- Wear in the hook, center pin, becket or threads of hook and nut.
- Play in the bearings.
- Spacer bolts, nuts and lynch pins.
- Cracks in welds.
- The condition of retainers, safety latch and grease nipples.

- Wear in holes in side plates and becket. / Wear of holes and play in the bearing supports.
- Worn sheaves.
- Contamination (dust, dirt, humidity) or corrosion of the roller bearings.
- Deformed or missing items or the presence of secondary retention.

If cracks or heavy gouges are apparent, the crane block shall not be used and competent opinion sought. Repairs should be undertaken by grinding smooth in the surrounding area only. If it is grooved and its section reduced by more than 5% from its nominal dimension, the item shall be replaced.

NDT of hooks shall follow surface inspection in accordance with EN 10228-1 class 3. The hook shall be replaced if its throat opening is enlarged by more than 10% from its certified dimension (Y-measurement).

By default and as a general rule for all sheaves, wear of sheaves should be evaluated both against 10% wear of nominal section thickness and 0.15xd in accordance with

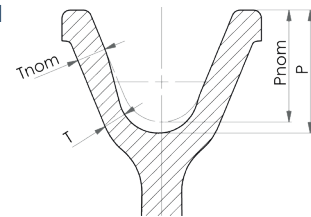

the DIN 15063 standard. For further detailed guidance on your particular sheave and application, contact your sales representative. Repair or modification by welding, flame torch, or other significant heat inducing method is strictly prohibited unless prior consent in writing has been obtained from Ropeblock.

Comprehensive and more intense regular examination must be carried out when your product is used in severe or corrosion inducing environments. High-grade steels may be susceptible to hydrogen embrittlement and loss of ductility. Check for cracks. Where stainless steel bolting is used, check for cathodic corrosion. If your block was fitted with retaining or securing wires, check that these are present, intact and correctly fitted.

If the holes in the cross head, side plates, becket or eyes are enlarged by more than 5% from nominal, the part shall be replaced. Items that are out of original tolerance, bent, deformed or misaligned shall be replaced. Employ sound engineering practice to evaluate and decide. Contact your sales representative for advice.

Any replacement parts shall be purchased from Ropeblock B.V. All repairs shall be carried out by trained and competent



personnel and great care shall be taken in the re-assembly of the equipment and fastening or securing parts such as grub screws, lynch pins, etc. Check and refit only correct sizes and threads. Nyloc nuts, should be replaced.

When properly maintained and kept at adequate grease levels, cylindrical roller bearings are designed to run one million cycles under their full dynamic catalogue rating and were selected to suit the perceived application. The thrust bearing is statically rated. Depending on the actual intensity of use and cumulative load throughout the product's life, fleet angles and environmental influences, the number of cycles could be higher or lower. With it, the effective life of the product itself compared to its original design life can be affected. Under severe (environmental, usage) conditions, more intense inspection and maintenance should be implemented.

As a general rule, sheaves, cross heads, bearings and bodies should be greased through nipples at these positions at least once a month or every 250 hours of service. Lubricate until new grease is visible. Heavy duty or high performance equipment should receive re-lubrication weekly. For sub-sea equipment, always remove the air-vent plug before the greasing operation to prevent jamming.

Bronze bearings should be greased every two weeks, or after 8 hours of continuous service. Check your product specifications or drawings for the location on your Ropeblock product.

Plain journal sheave bearings for submersible use must be greased less than one week prior to their first use. This is to reactivate the proper functioning of the bushing and combat potentially ageing and solidified grease.

Unless stated otherwise, re-lubrication, as well as maintenance, should be done with lithium or lithium/calcium based EP2 grease with a strong adherence to metallic surfaces, excellent protection against corrosion and resistance to wear and should be suitable for the required operating temperatures.

Retesting shall be done according to the requirements in the original test certificate and will only apply to a fully reeved component.

**FOR SPARE PARTS OR INFORMATION, OR IN THE EVENT OF ANY PROBLEMS OR DOUBT, ALWAYS CONTACT YOUR SALES REPRESENTATIVE OR ROPEBLOCK B.V.**

#### **SPARE PARTS LIST**

The recommended spare parts list indicates when the parts of the crane block should be replaced, or at least inspected and cleaned. If you do not have this, it is available on request.

**HIGH QUALITY AND SAFE COMPONENTS FOR THE GLOBAL LIFTING AND WIRE ROPE INDUSTRY.**  
**ROPEBLOCK.COM**





**ROPEBLOCK**

**SMART GETS  
YOU FURTHER.**

Copyright © 2020  
Published by Ropeblock B.V. All rights reserved.  
No part of this publication may be reproduced,  
stored in a retrieval system or transmitted in any  
form or by any means electronic, mechanical,  
photocopying, recording or otherwise without  
the prior written permission of the publisher.

Printing and typing errors reserved.  
Notice: No responsibility is assumed by the  
publisher for any injury and/or damage to  
persons or property as a matter of products  
liability, negligence, or otherwise, or from  
any use or operation of any methods, products  
or ideas obtained in the information herein.

**ROPEBLOCK.COM**