

SNATCH BLOCKS >>

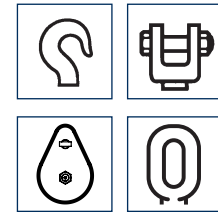

- Hook
- Clevis
- Tailboard
- Oblong eye

Model No.	WLL (UStons)	For wire ød (inch)	Dimensions (inch)								Weight (lbs)
			øD1	øD2	B	øH	T	TA	TB	TC/TL	
VB 355.22.1.14.S	15	7/8	16.1	14	13	1.4	1.9	16.6	3.6	35	190
VB 240.28.1.20.S	22	1 - 1 1/8	11.8	9.4	10	1.5	1.9	12.2	3.3	28.9	120
VB 300.32.1.20.S	22	1 1/8 - 1 1/4	14.4	11.8	11	1.5	1.9	14.8	3.3	31.4	130
VB 240.28.1.25.S	27.5	1 - 1 1/8	11.8	9.4	10	1.6	2.1	12.2	3.3	28.6	125
VB 300.32.1.25.S	27.5	1 1/8 - 1 1/4	14.4	11.8	11	1.6	2.1	14.8	3.3	31.2	140
VB 390.26.1.25.S	27.5	7/8 - 1	17.7	15.4	13.8	2.1	2.8	18.5	4.4	39.5	265
VB 240.28.1.27.S	30	1 - 1 1/8	11.8	9.4	10	1.7	2.2	12.2	3.3	32	150
VB 300.32.1.27.S	30	1 1/8 - 1 1/4	14.4	11.8	11.3	1.7	2.2	14.8	3.3	34.6	185
VB 345.32.1.32.S	35	1 1/8 - 1 1/4	15.7	13.6	12.8	2.1	2.8	16.1	4.4	37.4	265
VB 345.36.1.32.S	35	1 1/4 - 1 3/8	15.7	13.6	12.8	2.1	2.8	16.1	4.4	37.4	265
VB 390.32.1.32.S	35	1 1/8 - 1 1/4	17.7	15.4	13.8	2.1	2.8	18.5	4.4	39.5	310
VB 390.38.1.32.S	35	1 3/8 - 1 1/2	17.7	15.4	13.8	2.1	2.8	18.5	4.4	39.5	310
VB 430.32.1.32.S	35	1 1/8 - 1 1/4	19.5	16.9	14.8	2.1	2.8	20.1	4.4	41.3	330
VB 430.38.1.32.S	35	1 3/8 - 1 1/2	19.5	16.9	14.8	2.1	2.8	20.1	4.4	41.3	330
VB 520.32.1.32.S	35	1 1/8 - 1 1/4	23.4	20.5	17.1	2.1	2.8	24	4.4	45.6	660
VB 430.32.1.36,5.S	40	1 1/8 - 1 1/4	19.5	16.9	15.7	2.1	2.8	20.1	4.8	42.7	440

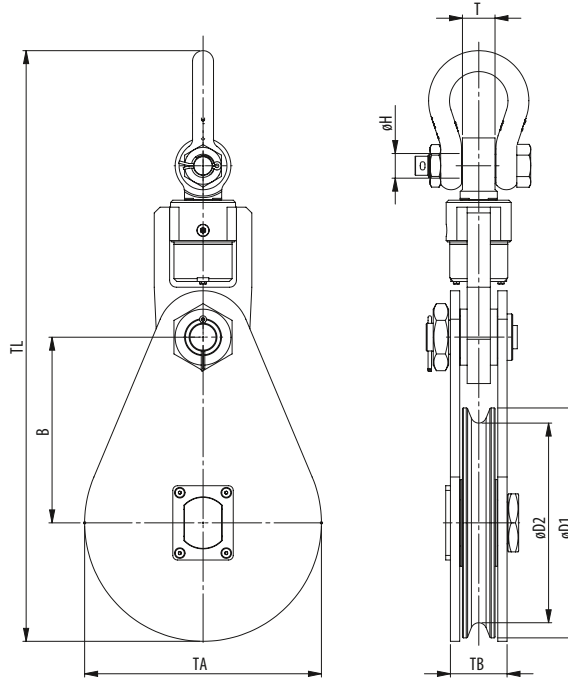

Minimum Ultimate Strength = 4 x WLL

WLL= Working Load Limit on head fitting.

- The dimensions in this table are indicative only. A drawing will always be submitted prior to production and will be the leading document when discussing dimensions.
- Blocks shown here are standard models; inquiries for custom versions are welcome.
- Refer to wire rope manufacturers D/d ratio guideline.
- Standard provided with bronze bearing. Roller bearing optional.



SEE OUR WARNING & SAFETY INFORMATION

<< SNATCH BLOCKS

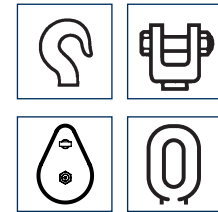
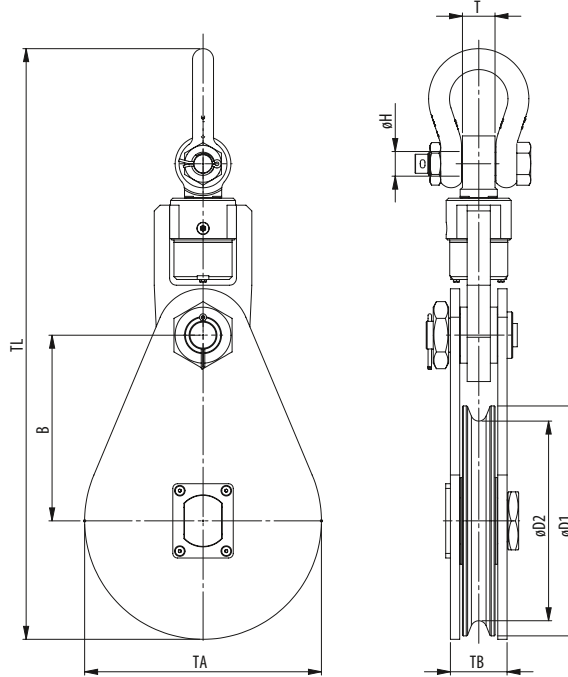

- Hook
- Clevis
- Tailboard
- Oblong eye

Model No.	WLL (UStons)	For wire ød (inch)	Dimensions (inch)								Weight (lbs)
			øD1	øD2	B	øH	T	TA	TB	TC/TL	
VB 430.38.1.36.5.S	40	1 3/8 - 1 1/2	19.5	16.9	15.7	2.1	2.8	20.1	4.8	42.7	440
VB 430.38.1.46.S	50	1 3/8 - 1 1/2	19.5	16.9	15.8	2.1	2.8	20.1	4.8	43.2	440
VB 520.38.1.46.S	50	1 3/8 - 1 1/2	23.4	20.5	18.1	2.1	2.8	24	4.8	47.5	550
VB 240.28.1.55.S	60	1 - 1 1/8	11.8	9.4	11.4	2.3	3.1	12.2	5.6	37.8	383
VB 520.38.1.55.S	60	1 3/8 - 1 1/2	23.4	20.5	18.1	2.3	3.1	24	5.6	50.4	680
VB 520.44.1.55.S	60	1 1/2 - 1 3/4	23.4	20.5	18.1	2.3	3.1	24	5.6	50.4	680
VB 520.52.1.55.S	60	1 3/4 - 2	23.4	20.5	18.1	2.3	3.1	24	5.6	50.4	680
VB 520.52.1.75.S	82.5	1 3/4 - 2	23.4	20.5	18.1	2.9	3.9	24	5.6	52.6	726
VB 630.58.1.75.S	82.5	1 3/4 - 2 1/4	29.5	24.8	22.4	2.9	3.9	30.3	8	71.5	1265
VB 710.68.1.100.S	110	2 1/2 - 2 5/8	31.5	28	25.6	3.4	4.7	32.3	8	75.2	1605
VB 800.76.1.125.S	137.5	2 3/4 - 3	35	31.5	29.5	3.4	4.7	36.2	8	84.6	2200

Also Available in Double Sheave Models:

VB 355.22.2.14.S	15	7/8	16.1	14	13	1.4	1.9	16.6	3.6	35	190
VB 240.28.2.20.S	22	1 - 1 1/8	11.8	9.4	10	1.5	1.9	12.2	3.3	28.9	120
VB 300.32.2.20.S	22	1 1/8 - 1 1/4	14.4	11.8	11.3	1.5	1.9	14.8	3.3	31.4	130

Minimum Ultimate Strength = 4 x WLL

WLL= Working Load Limit on head fitting.

- The dimensions in this table are indicative only. A drawing will always be submitted prior to production and will be the leading document when discussing dimensions.
- Blocks shown here are standard models; inquiries for custom versions are welcome.
- Refer to wire rope manufacturers D/d ratio guideline.
- Standard provided with bronze bearing. Roller bearing optional.



SEE OUR WARNING & SAFETY INFORMATION